

Electrical Distribution Equipment in Data Center Environments

White Paper 61

Revision 1

by Pearl Hu

Executive summary

IT professionals who are not familiar with the concepts, terminology, and equipment used in electrical distribution, can benefit from understanding the names and purposes of equipment that support the data center, as well as the rest of the building in which the data center is located. This paper explains electrical distribution terms and equipment types and is intended to provide IT professionals with useful vocabulary and frame of reference.

Introduction

Single-line vs. 5-line

Drawings or schematics that describe a data center's electrical design are usually referred to as single-line diagrams because all the wires (i.e. 3-phases, neutral, and ground) are represented by a single line connecting all the major components such as circuit breakers and transformers.

However, when there is a need for more detailed drawings that show the connections for all phase, neutral, and ground wires, a 5-line drawing is used. As the name suggests, 5-line drawings show all 5 wires of an electrical system and are useful to understand the effects of a ground fault, or circulating currents, or other anomalies that the electrical system may experience.

Electrical distribution systems are designed to power equipment in a safe and reliable manner. While many power distribution systems may, on the surface, appear very similar, there are specific attributes that distinguish them from each other. For IT professionals, the terminology can be very confusing – high voltage, medium voltage, low voltage; switchgear, switchboards, panel boards, power distribution units, etc. This paper defines these key terms, and provides an overview of the functions, placement, and standards for key electrical distribution equipment in data centers. Detailed equipment selection and design is not covered in this white paper.

Figure 1 provides a block diagram of an electrical distribution system showing the name and the typical location of the electrical distribution equipment in a data center and the power flow path. **This diagram is only an example of an electrical architecture and attempts to include all the possible major types of equipment used and their typical location in a data center.** In the real world, a typical data center electrical design has much more complexity and diversity than that in **Figure 1**. Some of the common variants are summarized in the “Summary of electrical equipment” section. Note that electrical designs are typically expressed as single-line diagrams (see side bar).

Figure 1

Block diagram showing an electrical distribution system in a data center

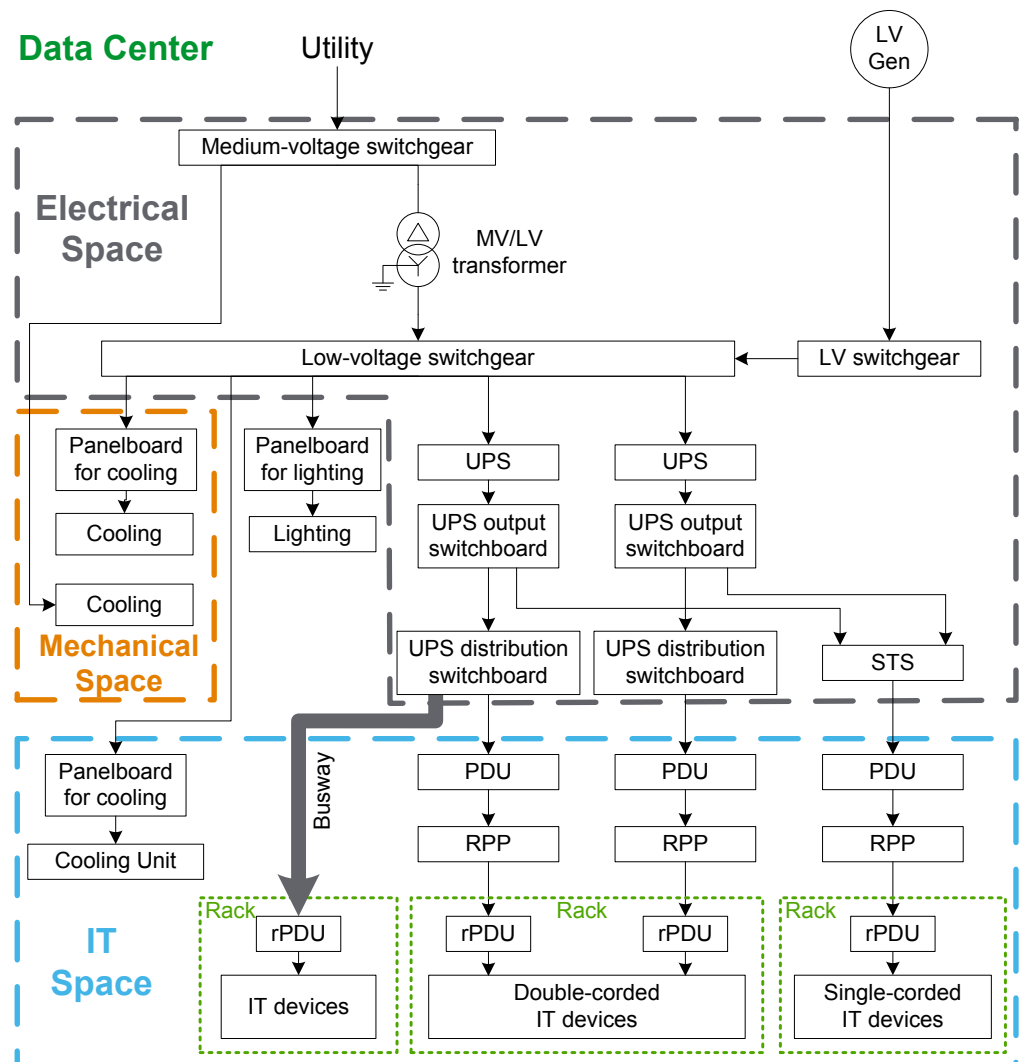

Voltages ratings in data center electrical distribution

Typically the utility supplies a medium voltage (MV) service to a dedicated data center. Then the MV is stepped down to low voltage (LV) by a MV/LV transformer located in the data center. LV power is distributed to the different electrical loads such as IT devices inside the racks, cooling system, lighting, etc by the electrical distribution equipment shown in the blocks in **Figure 1**. Some small data centers are supplied from utility pad-mounted transformers at low voltage, while large multi-megawatt data centers can specify the operational voltage level to be high voltage (HV) or MV. The type and location of the HV/MV substation can be contracted by the data center owner and the utility. Access to high voltage equipment including HV switchgear and HV/MV transformers is reserved for utility personnel and is not discussed further in this paper.

Voltage standards are usually stated using two values such as the IEC standard 400/230V¹ or the North American voltage 415/240V for high-efficiency green data centers². However, IT professionals still have difficulty understanding what this means. What is the relationship between these two values? What's the difference between the IEC and North American voltage standard? Why is 100-240Vac input voltage shown on the label of the servers in our data center? To better understand data center electrical distribution voltages, it is helpful to learn about the electrical distribution equipment itself.

Three-phase system vs. single-phase system

The electrical distribution in data centers is typically an alternating current (AC) three-phase system. The term “AC three-phase system” means that AC three-phase voltage is provided by each of the three separate coils of a transformer. The term “single-phase system” means that single-phase voltage is provided by a single transformer coil.

Transformers found in data centers are typically three-phase (three separate coils) and step down from a higher input voltage (also known as primary voltage) to a lower output voltage (also known as secondary voltage).

The terms “3-wire” and “4-wire” are often used to describe the electrical system design. The term 3-wire means that there are three “hot” conductors, line 1, 2, and 3 shown in **Figure 2**. While the term 4-wire means that in addition to three “hot” conductors there is a fourth “neutral” conductor. The neutral is required to supply line-to-neutral voltage to most IT loads as shown in **Figure 2**.

In addition to the wires described above, there is a final type of wire that is mandatory in all data centers called the “ground” wire or “protective earth” (PE). The purpose of the ground wire is to provide human safety against electrocution as well as protection of electrical equipment. This is accomplished by connecting a ground wire to all exposed metal parts of all equipment (including IT equipment) in the data center. In the event of a phase to ground fault, the ground wire acts as a low resistance path for current to flow which opens the circuit breaker or fuse.

In summary, there are two types of three-phase systems: 3-wire plus ground and 4-wire plus ground. In some regions, the 4-wire plus ground system is referred to as a 5-wire electrical system.

Figure 2 illustrates the different ways in which data center loads can connect to the electrical system. Single-phase loads, such as an IT server, are connected to one “hot” conductor and

¹ The designation of the two values when written as “400/230” represents the line-to-line voltage (the higher value) and the line-to-neutral voltage (the lower value).

² Refer to White paper 128, [Switching to 240V AC Distribution in North American Data Centers](#)

the “neutral” conductor (Load M). Some single-phase loads such as 208V IT equipment in North America, are connected to two “hot” conductors (Load N). Three-phase loads, such as a three-phase remote power panel, are connected to three “hot” conductors (Load P). Finally, three-phase loads, such as chillers and pumps, are connected to three “hot” conductors (Load Q). In all of these examples, the loads are all connected to the “ground” wire for safety.

Figure 2

Example of three-phase system with transformer and loads

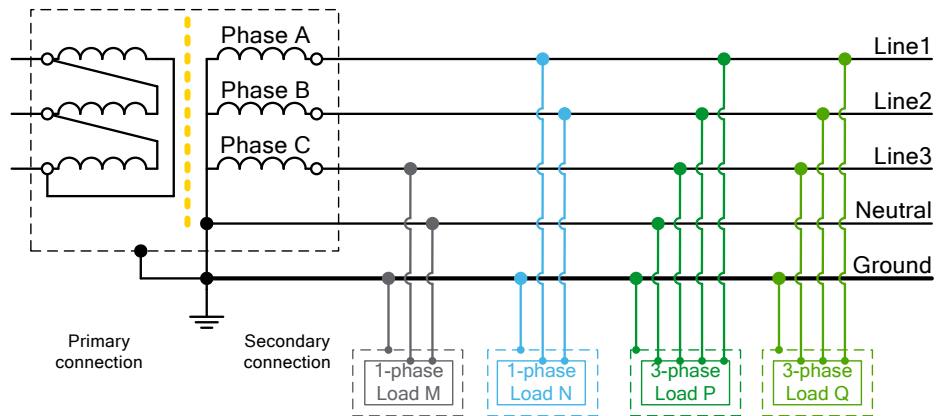

Rated electrical supply voltage

The electrical supply voltage is the voltage that is applied to the terminals of electrical equipment. While this voltage can be measured, the **rated** electrical supply voltage cannot because it is defined by the local national standards and is dependent on where the data center is located. **Table 1** lists the common rated supply voltage (or nominal voltage) for North America, South America, Europe, China, and Japan. The actual measured supply voltage in the data center may be slightly higher or lower than the nominal voltage due to the permissible system tolerance (i.e. +/-10%).

Table 1

Rated system voltages for various regions

Location	Nominal Medium-voltage ³	Nominal Low-voltage ¹
North America	4.16kV 13.8kV 34.5kV	600 3-wire+ground (primarily Canada) 480Y/277 4-wire+ground 480 3-wire+ground 208Y/120 4-wire+ground 415/240V 4-wire+ground (new data centers)
South America ⁴	6kV 11 kV 13.8kV 22kV 23kV	220Y/127 60Hz 4-wire+ground (ranges from 110 to 127V) 380Y/220 60Hz 4-wire+ground (ranges from 220 to 240V) 400Y/230 50Hz 4-wire+ground (ranges from 220 to 230V)
Europe	10kV 20kV 35kV	400Y/230 50Hz 4-wire+ground 480Y/277 60Hz 4-wire+ground
China	10kV 35kV	380Y/220 4-wire+ground
Japan	6.6kV 22kV	200 3-wire+ground 1-phase 200/100 3-wire+ ground 1-phase 100 2-wire+ ground

³ The term medium voltage (see IEV-01-28) here is commonly used for the distribution system with voltage above 1kV and generally applied up to and including 52kV.

⁴ Varies widely between [countries](#) (last accessed 12/30/2013).

Current ratings in data center electrical distribution

Arc flash and safety

The term “arc flash” describes what happens when an electrical short circuit occurs through the air. This type of short circuit usually occurs between a live conductor (i.e. wire, bus) and another live conductor(s) or ground. In most cases, a single-phase short circuit evolves into a three-phase short circuit.

The heat energy from the arc causes the metal parts to vaporize into small molten particles called plasma, this conductive plasma further lowers the resistance between conductive parts which allows more current to flow, leading to more heat energy, higher temperatures, and ultimately more damage to property and harm to any personnel nearby. Given enough energy, a pressure wave develops with significant force and is referred to as an arc blast.

In the event of an arc flash, circuit breakers must be able to handle the maximum fault current available at their inputs.

There are various current ratings for electrical equipment in data centers. For simplicity, only a few key ratings are discussed in this paper.

Rated current

Every device has a limit on how much steady-state current it can safely support, otherwise known as its **rated current**. The rated current of electrical equipment means that the equipment can continuously support that current without exceeding its temperature limit (i.e. temperature rise) at a certain condition. Exceeding the temperature limit on electrical equipment can lead to equipment failure or even fire.

The IEC60059 standard R10 series specifies standard ampere ratings of electrical equipment and devices as 1, 1.25, 1.6, 2, 2.5, 3.15, 4, 5, 6.3, 8 as well as their multiples of 10^n (n is positive integer). While in North America, the ANSI (American National Standard Institute) standard or IEEE (Institute of Electrical and Electronics Engineers) standard lists the standard ampere rating as 15, 20, 25, 30, 35, 40, 45, 50, 60, 70, 80, 90, 100, 110, 125, 150, 175, 200, 225, 250, 300, 350, 400, 450, 500, 600, 700, 800, 1000, 1200, 1600, 2000, 2500, 3000, 4000, 5000, and 6000 amperes.

Over-current ratings

All electrical components in the data center must be protected against over-current conditions such as overloads and short circuits. The key is that all components in **a circuit should be protected from the effects of the maximum available fault current they may encounter (see side bar)**.

Some over-current ratings apply **ONLY** to over-current protection devices (OCPD) (i.e. circuit breakers and fuses) which are responsible for opening a circuit upon over-current conditions. While other ratings apply to **BOTH** protection devices and assemblies (i.e. switchboards, bus bars, wires, panel boards, etc.)⁵, which must be able to withstand short periods of over current conditions before the OCPD is activated.

Two examples of over-current ratings that apply **ONLY** to over-current protection devices are

- **Overload relay trip-current rating** - an adjustable setting on some types of circuit breakers that opens the breaker upon an overload
- **Rated ultimate short-circuit breaking capacity** equivalent to **ANSI/IEEE’s kilo ampere interrupting capacity (KAIC)** - the highest value of current that a circuit breaker is capable of breaking at its rated voltage without being damaged

One example of an over-current rating that applies to **BOTH** protection devices and assemblies is

- **Rated short-circuit withstand current** similar to the **North American National Electric Code’s (NEC) short-circuit current rating (SCCR)** - the maximum permissible short-circuit current that the equipment can withstand, thermally and electro-dynamically, without sustaining damage, for a given time period.

⁵ *Guide to the Application of Short-Circuit Parameters in Low-Voltage AC Circuits*, BEAMA Installation, November 2003, issue 1

Electrical distribution systems

There are many different loads in the data center, such as IT equipment, air conditioners, fans, pumps, lighting, etc. The flow and transformation of energy from the utility/generator to the load is enabled by various types of equipment. The terms upstream and downstream are commonly used to describe the location of equipment or a fault (i.e. the transformer upstream of the UPS). The term upstream indicates a direction toward the utility and the term downstream indicates a direction toward the data center loads. Tracing the flow of energy along its path (starting from the utility to the IT loads) in **Figure 1** illustrates the following types of equipment:

- Medium-voltage switchgear including MV/LV transformer
- Low-voltage switchgear/switchboard / automatic transfer switch (ATS)
- UPS system with input/output switchboard and UPS distribution switchboard
- Power distribution Units (PDUs) and remote power panels (RPPs)
- Busway
- Panelboard
- Rack PDUs (rPDUs) / outlet strips

All the equipment in the list above, except for rack PDUs (rPDUs), are considered to be assemblies containing circuit breakers, switches, various types of relays, buses and connections, and control and auxiliary devices⁶. This equipment is used to distribute power to the downstream loads and to protect the power distribution system in the data center. Each device is optimized for long life and ease of maintenance. The following subsections introduce each type of equipment.

Medium-voltage switchgear including MV/LV transformer

Medium-voltage switchgear is generally located in the electrical space of large-capacity data centers (i.e. greater than 1 MW IT load). This equipment is typically fed directly from the utility and usually marks the utility service entrance to the building. If a MV generator is present, it also feeds the MV switchgear. **Figure 3a** shows an example of MV switchgear. Other than simply distributing power, the MV switchgear is responsible for disconnecting faults and controlling the MV power distribution system, for example, when isolating a redundant section for maintenance. MV switchgear typically includes meters, breakers, contactors, fuses, surge arresters, earthing switches for IEC equipment, voltage/current transformers, control and protection relays, and an overall control system.

Basically medium-voltage switchgear is the assembly of the following four cubicles as shown in **Figure 3b**: incoming unit or main section, outgoing unit or feeder section, voltage metering unit, and bus section or tie section/breaker. The outgoing unit distributes three-phase power to the primary (upstream) side of the MV/LV transformer. Due to safety distances at MV, typically each cubical is limited to only one MV circuit breaker.

⁶ The IEC 61947 & IEC 62271, which specifies the HV and LV switchgear terminology, considers switchboard to be the same as switchgear. While in North American, switchgear and switchboard are specified differently by ANSI and UL standards. See "Appendix A" for a detailed explanation.

Figure 3

MV switchgear and its one-line diagram

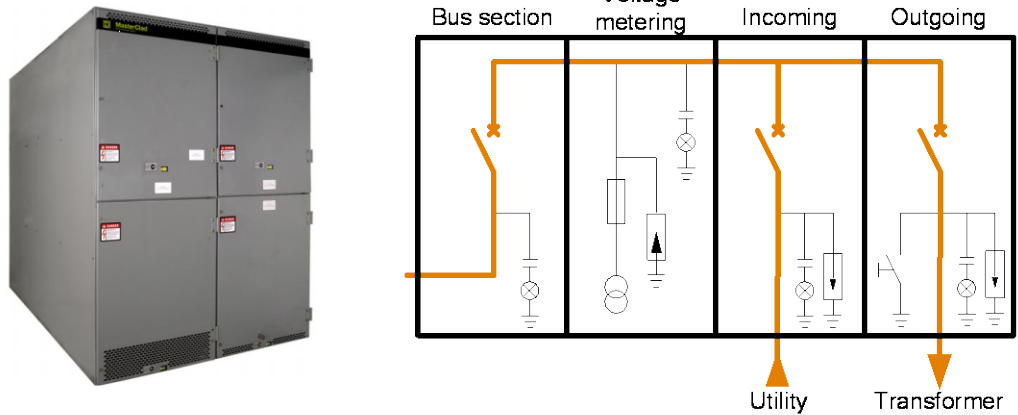

(a) Picture of MV switchgear

(b) One-line diagram of MV switchgear

The following are some typical electrical parameters for MV switchgear. Values for these parameters vary according to local regulations:

- Voltage ratings – Two key voltage ratings for MV switchgear are rated voltage and rated lightning impulse voltage (equivalent to the ANSI basic impulse level i.e. BIL). For example, an ANSI MV switchgear solution may have a rated voltage of 15kV and 95kV BIL (i.e. impulse voltage).
- Current ratings – The rated current of MV switchgear is always specified by the manufacturer. Another key current rating is the rated short-circuit withstand current similar to the North American National Electric Code’s (NEC) short-circuit current rating (SCCR). For example, an ANSI MV switchgear solution may have a rated current of 1200A and 40kA SCCR.

Dry type transformers, with and without an enclosure shown in **Figure 4**, are installed in the electrical space to step down medium voltage from the MV switchgear to low voltage for the downstream power distribution equipment. The key electrical parameters of MV/LV transformers include: rated power (i.e. 2500kVA), primary and secondary voltage (i.e. 10kV/400V), and impedance (similar to resistance) specified as %Z (i.e. 5%).

Figure 4

Photos of MV/LV dry type transformer with and without enclosure



(a) MV/LV dry type transformer



(b) Dry type transformer with enclosure

Low-voltage switchgear/switchboard / automatic transfer switch (ATS)

Typically LV switchgear/switchboard is located in the electrical room and marks the utility service entrance for data centers less than 1 MW. An example of LV switchgear is shown in

Figure 5a. If a LV generator⁷ is used, the generator would feed the LV switchgear. Apart from distributing power, the LV switchgear is responsible for disconnecting faults and controlling the LV power distribution system. A device known as an automatic transfer switch (ATS) has traditionally been used to switch between utility and generator. However, the current trend is to have LV breakers perform this function in lieu of the ATS device. Note that in the case of a medium voltage generator, this transferring function occurs at the medium voltage switchgear level.

Figure 5

Example of LV switchgear and its one-line diagram

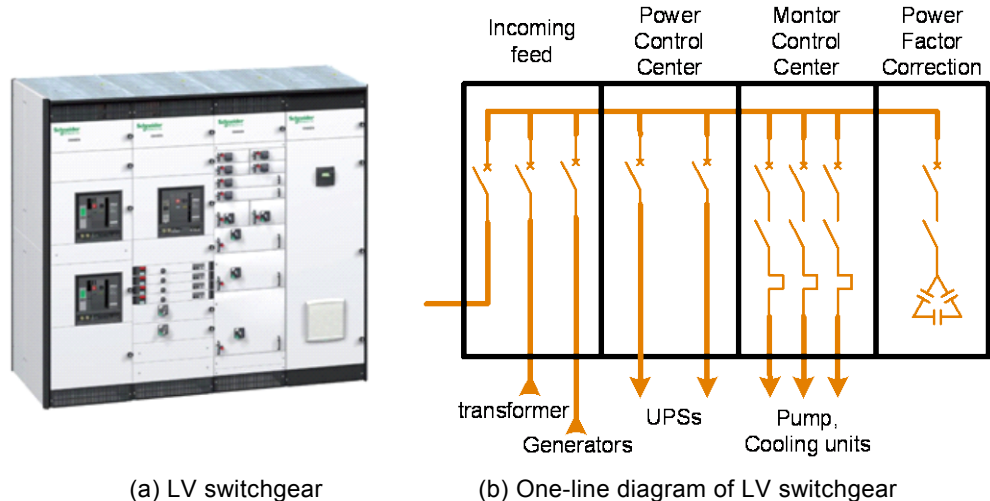

LV switchgear/switchboard installed in a data center is typically a combination of some of the following functional units: incoming feeder from the secondary side of the MV/LV transformer or LV generators, power control center (PCC, i.e. for downstream UPS), motor control center (MCC, i.e. for pumps), the power factor correction/harmonic filtering and the bus connections. The following devices are always assembled in LV switchgear: horizontal busbar, vertical busbar, circuit breakers, meters, switches, surge arresters, relays, etc.

The following are the key electrical parameters of the LV switchgear. The values for these parameters vary according to local regulations:

- Voltage ratings – Two key voltage ratings for LV switchgear are rated voltage and rated lightning impulse voltage. ANSI does not specify the impulse voltage for LV switchgear. For example, an IEC LV switchboard solution may have a rated voltage of 690V and 12kV rated impulse withstand voltage.
- Current ratings – The rated current of LV switchgear is always specified by the manufacturer. Another key current rating is the rated short-circuit withstand current similar to the North American National Electric Code's (NEC) short-circuit current rating (SCCR). For example, an IEC switchgear solution may have a rated current of 5000A and 85kA rated short-circuit withstand current.

UPS

UPS systems are typically installed in the electrical space or IT space of the data center to provide uninterrupted power to the critical equipment it supports. The UPS design configuration chosen directly impacts the availability of critical IT equipment. See White Paper 75, [Comparing UPS System Design Configurations](#), to select the appropriate design according to the availability needs.

There are various types of UPSs available, depending on the application, which are discussed in White Paper 1, [The Different Types of UPS Systems](#). Some examples of UPSs are

⁷ For more information on generators see White Paper 93, [Fundamental Principles of Generators for Information Technology](#)

shown in **Figure 6**. UPS batteries typically provide about 15 minutes of the ride-through, at full load, which allows back-up generators to start in the event of a utility failure. The following devices are typically installed inside UPSs: input/output switches, bypass switches, static switches, power modules including the rectifiers and inverters, and their control and communication modules.

Figure 6

Examples of UPSs:
 (a) Galaxy 7000
 (b) Symmetra PX modular UPS



(a) Galaxy 7000 UPS



(b) Symmetra PX modular UPS

Depending on the size of data center and system's availability requirements, UPS configurations include some of the following electrical equipment: UPS, UPS input switchboard, UPS output switchboard, UPS distribution switchboard, and static transfer switch (STS) for bypass. Depending on the design architecture and business requirements, the three following types of LV equipment may be located along side of the UPS in the electrical room.

Figure 7

One-line diagram of:
 (a) UPS input switchboard
 (b) UPS output switchboard;
 (c) UPS distribution switchboard

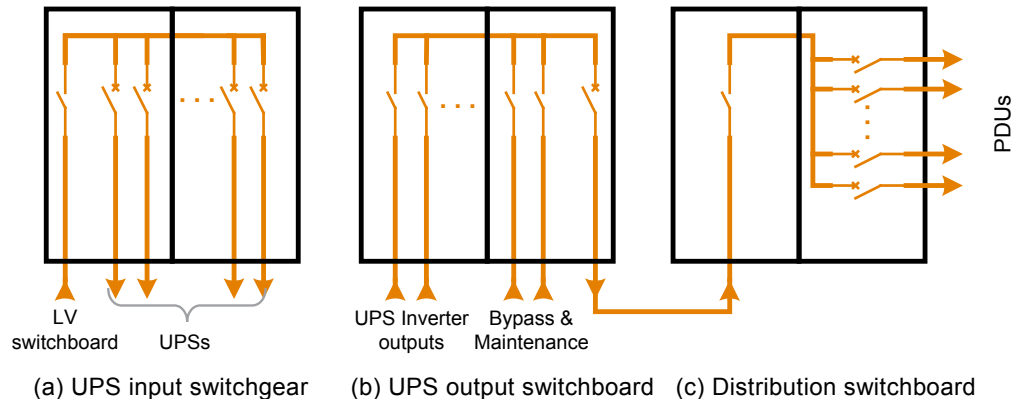

The UPS input switchboard feeds to UPS from power control center of the upstream LV switchgear/switchboard as shown in **Figure 7a**. While the UPS output switchboard, as shown in **Figure 7b**, not only provides the power from UPS output to the downstream circuits, but also consists of the static bypass circuit breakers and maintenance bypass circuit breakers to allow utility power to clear faults or isolate the UPS for maintenance. In some cases, isolation transformers are installed in the input or output switchboard as well. See White Paper 98, [The Role of Isolation Transformers in Data Center UPS systems](#), for more information on this topic. In data center applications, UPS power ratings range from about 20kW to 1,600kW. Paralleling multiple UPS can provide higher capacities and or UPS module redundancy. The UPS distribution switchboard, shown in **Figure 9c**, distributes power to the different PDUs. These three switchboards can be assembled in one or more cabinets depending on the complexity of system architecture and the quantities of the circuit breakers and switches. The three LV switchboards above typically include the incoming feeder, the outgoing branch circuit, and the bus connection.

UPS input/output switchboard and UPS distribution switchboard can be provided by the UPS supplier as optional accessories. It can also be provided by switchgear/switchboard vendors.

Power distribution Units (PDUs) and remote power panels (RPPs)

Traditional PDUs and RPPs are located in the IT space to distribute, control, and monitor the critical power from the upstream UPS system to IT racks. See White Paper 129, [Comparing Data Center Power Distribution Architectures](#), to learn about the five data center power distribution approaches. PDUs usually contain a main input circuit breaker, branch circuit panelboard(s), a power transformer, output power cables, surge arrestor, and the monitoring and communication modules. Sometimes PDUs with power transformers can generate a new “grounded” neutral for the downstream IT loads; in North American data center PDUs with power transformers are mainly used to step down 480 Vac to 120/208 Vac⁸; while in Japan, PDUs with power transformers step down 200Vac to 100Vac single-phase for the downstream IT loads. A PDU is typically rated from 50kW to 500kW.

Figure 8

Traditional PDUs:
(a) fire-wired PDU;
(b) factory-configured PDU

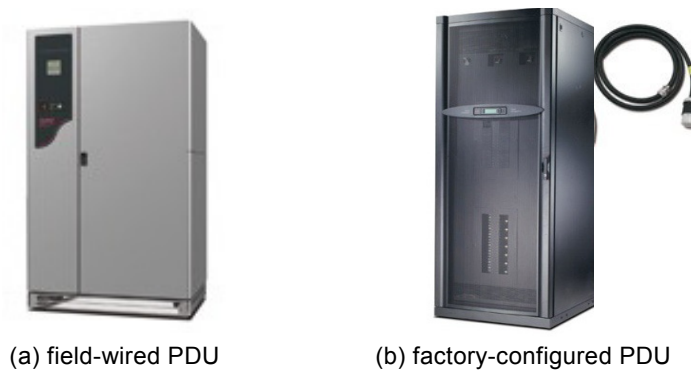

A switching device, called a static transfer switch (STS), is sometimes integrated into the PDU cabinet located in the IT space or is also available as stand-alone cabinets located in the electrical space. Referring to **Figure 1**, an STS has two inputs from the UPS system and one output to the downstream PDU. STS is commonly used to provide concurrent maintenance in a distributed redundant configuration. It typically provides fast (1/4 cycle) open transition switching between two different UPS feeder systems, thus keeping the load on protected power at all times. See White Paper 62, [Powering Single-Corded Equipment in a Dual Path Environment](#) for more information on this topic.

Remote power panels (RPPs) are like PDUs without a transformer and are therefore smaller, having a footprint about the size of a standard 2’x2’ raised floor tile. RPPs may contain up to four panelboards and a monitoring system, and distribute power to the IT racks. RPPs are most often fed from one or more PDU sub-feed breakers.

Busway

Busway is an alternative to traditional power distribution using PDUs and RPPs (**Figure 1**). Busway usually includes the feed unit connected with an upstream LV electrical switchboard, the power bus, the plug-in units or tap-off unit equipped with the over-current protection devices, the connection fittings and their accessories. One example of busway with 2N redundancy mounted overhead in IT space is shown in **Figure 9**. Busway can be mounted under floor in the IT space as well. See White Paper 129, [Comparing Data Center Power Distribution Architectures](#), to learn about modular busway and its advantages and disadvantages.

⁸ There is a trend in North America to move to step down to 240 Vac as discussed in White paper 128, [Switching to 240V AC Distribution in North American Data Centers](#)

Figure 9

One example of busway with 2N redundancy mounted overhead in IT space

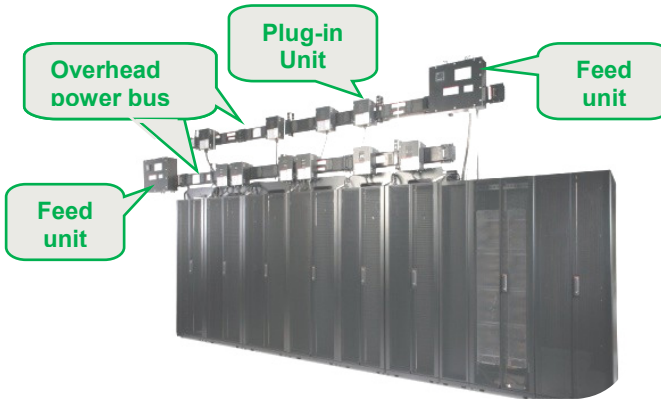

Panelboard

Panelboards (typically rated from 1.5kVA to 75kVA) are basically a metal cabinet that house the main electrical bussing and the terminals upon which circuit breakers, neutral wires, and ground wires are installed. Panelboards are common in the mechanical space, electrical space, and IT space to distribute the power to cooling equipment (i.e. chillers, pumps, fans, etc.), lighting, and security devices. They are typically mounted against a wall or on steel bracings and are accessible only from the front as shown in **figure 10**. Generally speaking, the term panelboard is market nomenclature for wall-mounted LV switchboard⁹.

Figure 10

Example of panelboards



In data centers, panelboards are sometimes used in place of, or in combination with, RPPs. However, in most cases, the panelboards are assembled in a cabinet like PDUs and RPPs to distribute the power to the IT racks. In general, a single branch-circuit panelboard has 42 pole positions which can accommodate 42 single-phase branch circuit breakers.

Rack PDUs (rPDUs) / outlet strips

Rack PDUs (i.e. power strips) are installed in IT racks and are powered from the mating connector of the upstream PDU or RPP and distribute power directly to IT equipment in the rack. Three-phase rPDUs or one-phase rPDUs are selected based on the expected rack power density and or system configuration.

Figure 11

Example of rack PDU



⁹ See "Appendix A" for the detail explanation.

Metered rack PDUs provide real-time remote monitoring of connected loads. User-defined alarms warn of potential circuit overloads before critical IT load drops. Switched rack PDUs provide advanced load monitoring combined with remote on/off switching control of individual outlets for power cycling, delayed power sequencing, and outlet use management.

In summary, the job of the rack PDU, PDU, RPP, busway and panelboard in **Figure 1** is to distribute three-phase power to critical, single-phase IT devices at the rack PDU outlets.

Summary of electrical equipment

Except for MV switchgear and UPS, almost all of the switching equipment in a data center can be called LV switchgear/switchboard or switchboards. Different names are assigned only for market nomenclature or through habit.

Though **Figure 1** presents one example of the data center architecture to cover the possible electrical equipment, some of the common differences / variants are mentioned below:

- MV generator can replace the LV generator as the backup energy source feeding the MV switchgear.
- UPS systems may be located in the IT space or in the row of IT racks for smaller data centers.
- PDUs can distribute the power to the IT racks directly thereby avoiding the use of RPPs.
- STS can be integrated in the PDU cabinet to provide distribution redundancy. Rack-mounted automatic transfer switches can be another solution to provide the redundancy. See White Paper 48, [Comparing Availability of Various Rack Power Redundancy Configurations](#) to seek the reasonable solution for higher availability.
- Cooling units in the IT space can be fed by the UPS if continuous cooling is required during a power outage.
- Busway alone can provide all LV power distribution from the LV switchgear/switchboard to IT racks.
- UPS input power can be derived from the LV switchgear/switchboard directly to the UPS thereby eliminating the need for an input switchboard.
- The UPS output switches and distribution switches may be assembled in one LV switchboard.
- An integrated UPS system may include the input, output, or distribution switchboard.

Generally the data center architecture depends on the data center capacity, the system redundancy, the IT racks arrangement, and the equipment providers etc.

Table 2 shows some key parameters of electrical distribution equipment found in a data center. This table does not include other devices such as UPS, and generators since they are not considered distribution equipment.

For MV and LV switchgear/switchboard, the power rating depends on the nominal voltage and the rated current of the switchgear. However, maximum power of the MV switchgear is always limited by the maximum power capacity from the utility. The maximum power rating of LV switchgear/switchboard is generally limited by the capacity of the MV/LV transformer and the maximum current rating of LV circuit breakers. The cost of electrical distribution equipment (per kW of data center capacity) varies widely depending on the current rating, voltage rating, number of breakers, number of cabinets, and redundancy. The equipment cost values indicated in **Table 2** are based on 1N power distribution. See TradeOff Tool 4, [Data Center Capital Cost Calculator](#), to estimate the capital cost of different data center designs.

Note that the number of circuit breakers and cabinets used in a particular design play a dominant role in equipment cost, as shown in the table. Data centers below 2MW of IT

capacity (no redundancy) have about 4 to 7 LV switchgear circuit breakers per megawatt of IT capacity. Data centers below this capacity typically have one MV circuit breaker that is owned the utility company. The number of LV switchgear breakers per MW of IT capacity can easily double with increased redundancy and concurrent maintenance design schemes. Data centers greater than 20MW of IT capacity, tend to have more MV breakers than LV switchgear breakers.

A data center’s electrical system, including the UPS and generator, represents 40-50% of the data center capital expense (not including the building). Of this amount, the equipment represents 50-60%, installation represents about 25-35%, and design represents 15-20%. Further breaking down the equipment costs, the UPS and generator represent about half of the electrical equipment cost, while the other half is composed of switchgear, transformers, panelboards, PDUs, and rack PDUs.

Table 2

Comparison of some key electrical distribution equipment in data centers

Parameter	MV Switchgear	Transformers	LV Switchboard	Panelboard	PDU/RPPs
Location	Electrical Space	Electrical space, IT room	Electrical Space	Electrical space, mech space, IT room	IT room
CB type	Vacuum CB	N/A	Air CB; MCCBs;	MCCBs; General CBs	MCCBs; General CBs
Rated voltage	MV	LV and MV	LV	LV	LV
Power rating	4-50MVA	50kVA-50MVA	100kVA-6MVA	1.5kVA-75kVA	50kW-500kW
Equipment cost per kW of data center capacity	\$8 - \$92	\$35 - \$90	\$80 - \$200	\$20 - \$40	\$100 - \$400

Conclusion

Electrical distribution equipment is the backbone of the data center as it provides the power path to all of the equipment in the data center, such as IT devices, cooling units, security, and lighting. More importantly this equipment ensures the safety of all personnel and equipment. IT professionals should have a general knowledge of a data center’s electrical system as described in this paper.



About the author

Pearl Hu is a Senior Research specialist at Schneider Electric's Data Center Science Center. She holds bachelor’s degree in Electrical Engineering from the Taiyuan University of Technology and a master’s degree in Power Electronics from the South China University of Technology. Before joining Schneider Electric, Pearl worked in General Electric R&D center (China) and Emerson Network Power. She is now designated as a “Data Center Certified Associate”, an internationally recognized validation of the knowledge and skills required of a data center professional.



Resources



[The Different Types of UPS Systems](#)

White Paper 1



[Powering Single-Corded Equipment in a Dual Path Environment](#)

White Paper 62



[Comparing UPS System Design Configurations](#)

White Paper 75



[The Role of Isolation Transformers in Data Center UPS systems](#)

White Paper 98



[High-Efficiency AC Power Distribution for Data Center](#)

White Paper 128



[Comparing Data Center Power Distribution Architectures](#)

White Paper 129



[Browse all white papers](#)

whitepapers.apc.com



[Data Center Capital Cost Calculator](#)

TradeOff Tool 4



[Browse all TradeOff Tools™](#)

tools.apc.com



Contact us

For feedback and comments about the content of this white paper:

Data Center Science Center
dcsc@schneider-electric.com

If you are a customer and have questions specific to your data center project:

Contact your Schneider Electric representative at
www.apc.com/support/contact/index.cfm

Appendix A: Switchgear, Switchboard & Panelboard

Appendix A clarifies the strict definition and the followed standard of switchgear, switchboard, and panelboard applied in the data center located in US.

- Switchgear operating in the medium voltage range and in the high voltage range meets the applicable IEEE/ANSI C37 standards.
- All switchgear operating at low voltage meets the of IEEE/ANSI C37.20.1 & UL 1558 standards. Switchgear incorporates only power circuit breakers which conform with ANSI C37.13, NEMA SG-3 and are listed per UL1066. These power breakers are over 10 times physically stronger than molded case circuit breakers. Power breakers may require periodic maintenance to enable a long service life.
- A dead-front switchboard is tested to and listed as UL 891 and is classified as low voltage equipment. Switchboards may include any combination of protective devices including insulated case (ICCB), molded-case circuit breakers (MCCB) listed per UL-489, fusible switches listed per UL 508 and UL 977 and power circuit breakers listed to UL 1066. Switchboards may be accessible from the rear as well as from the front and are not intended to be installed in cabinets.
- Panelboards are constructed and tested in accordance with UL 67 “Standards for Panelboards”, and UL 50 “Enclosures for Electrical Equipment”. Panelboards are classified as low voltage equipment and are further restricted for use depending on the voltage of the circuit breakers chosen for use within a panelboard and accessible only from the front.