

CMGT 235 Electrical and Mechanical Systems
Exam #3 – Electrical Systems

Use the NEC. SHOW ALL WORK FOR FULL CREDIT

Name: _____

- [10 pts] 1. A single-phase, 240-volt air-conditioner is being installed for a small commercial building. The nameplate reads: "Minimum Circuit Ampacity 40 Amperes." The circuit originates at the main panel located 125 ft from the air-conditioner unit. What is the permitted voltage drop? What is the minimum size THWN CU conductors required and where in the NEC do you find this? What is the voltage drop due to the conductors? Does it meet the code requirement? If not, what should be done to meet the code?

[18 pts] 2. Sizing Conductors

What is the smallest trade size EMT nipple required to enclose 3 each 3/0 THHN conductors and 1 #4 THHN ground between two panels?

QTY	GAUGE	TYPE	Cross-Section Area	
				EMT Nipple
Total Cross-Section Area				

What is the smallest trade size rigid metal raceway required for installing XHHW copper conductors in a conduit over 24 inches long with (2) 400 kcmil, (6) 500 kcmil and (1) bare 3/0?

QTY	GAUGE	TYPE	Cross-Section Area	
				RMC
Total Cross-Section Area				

What is the smallest trade size PVC Sched 40 raceway required for installing THW-2 copper conductors in a conduit over 24 inches long with (2) 4/0?

QTY	GAUGE	TYPE	Cross-Section Area	
				PVC Sched. 40
Total Cross-Section Area				

How many 2/0 XHHW conductors can be installed in a trade size 2 ½ Liquidtight Flexible Metal Conduit (LFMC)?

- [15 pts] 3. A job site is powering two of the temporary lights described below with a 120VAC portable diesel generator. If the lowest the lamp voltage can be is 115V, determine the maximum length for a 18/3 CU uncoated and 16/3 CU uncoated extension cord. The lamps are wired in parallel and the light cord can be neglected.

Specifications: Temporary Job Site Light, Light Distribution Flood, Lamp Type Halogen, Number of Lamp Heads 2, Voltage 120VAC, Lamp Watts 1000, Lumens 16,000, Color Copper, Base Style Floor Stand, Job Site Lighting Max. Height 63 In., Not Safety Rated, Lamp Included Yes, Rated Life 2000 hr., Cord Length 5 ft., NEC Cord Designation SJTW, Gauge/Conductor 18/3, NEMA Plug Configuration 5-15P, Guard Type Metal, Replacement Lamp 500W 4-5/8 In.

Hint: Draw the circuit.



- [5 pts] 4. Determine the total resistance and the value of R3.

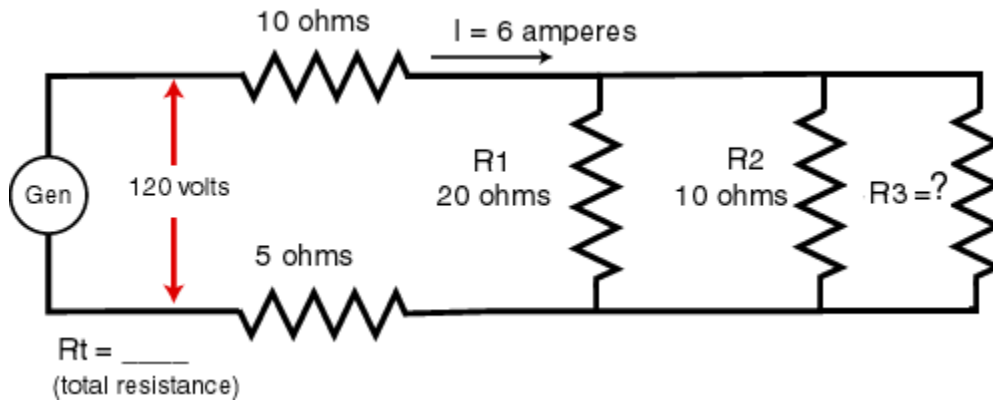

- [5 pts] 5. What is the power factor for a three-phase system operating when the wattmeter reads 6,000 watts, the voltmeter reads 208 volts, and the ammeter reads 20 amperes?

- [5 pts] 6. Given a single-family residence with a general lighting load of 22,500 watts. What is the demand lighting load for the residence?

- [5 pts] 7. What is the minimum lighting load required for the general lighting (only) of a church building having outside dimensions of 100 ft x 200 ft?
- [5 pts] 8. What is the demand load for a ½ hp 120VAC food waste disposal, a 1000-watt 120VAC dishwasher, and a 12A 120VAC Hydro Tub?
- [5 pts] 9. What size grounding electrode conductor is required for a 13,000 sq. ft. commercial building that has installed 4/0 copper ungrounded service-entrance conductors?
- [5 pts] 10. 20-volt, 20-ampere GFCI protected residential branch circuit may be buried at a minimum depth of?
- [4 pts] 11. What is the maximum allowable trade size for:
Electrical Metallic Tubing _____
Rigid Metal Conduit _____
- [5 pts] 12. A disconnecting means shall be provided and be accessible, located within sight from all pools, spas, and hot tub equipment, and shall be located at least how many feet from the inside walls of the pool, spa, or hot tub?

[5 pts] 13. What size Over Current Protection Device (OCPD) is recommended for a 6500 W, 208V sauna?

[8 pts] 14. A 100 A 120 V 24 circuit house panel is supplying current on circuit #2 to the following loads:

Toaster	900 W
Coffee Maker	1200 W
Blender	800 W

If all the appliances are on simultaneously:
What is the total current from the receptacle load?

What size OCPD would be required?