

## Equilibrium of a Nonconcurrent Coplanar Force System

**Independent Equations**

Three independent equations can be used to solve for three unknowns.

**Equilibrium Equations:**

$$\sum F_x = 0$$

$$\sum F_y = 0$$

$$\sum M_A = 0 \text{ (about any point)}$$

**Alternative Equations Containing Two Moment Equations:**

$$\sum F_x = 0$$

$$\sum M_A = 0$$

$$\sum M_B = 0$$

where the x-axis is chosen arbitrarily and A and B are arbitrary points, except that line AB must not be perpendicular to the x axis.

**Alternative Equations Containing Three Moment Equations:**

$$\sum M_A = 0$$

$$\sum M_B = 0$$

$$\sum M_C = 0$$

where A, B, and C are arbitrary but noncollinear points.

**Which Equations to Use?**

Choosing equations properly can result in only having one unknown in the equation that can be solved for immediately.

Equations containing one unknown may be obtained by writing the moment equation about the point of intersection of the other two unknowns.

If two of the unknown forces are parallel, the third unknown may be determined by summing the force components in a direction perpendicular to the two parallel unknown forces.

Determine the reaction components at the supports of the beam subjected to the loads as shown.

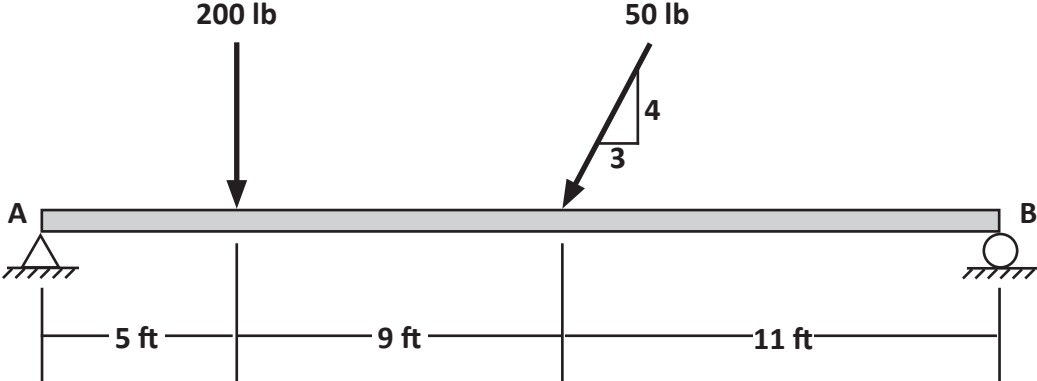

Solution.

The beam shown carries a distributed load as shown. Neglect the weight of the beam.

(a) Sketch the FBD of the beam

(b) Find the reactions at A and B

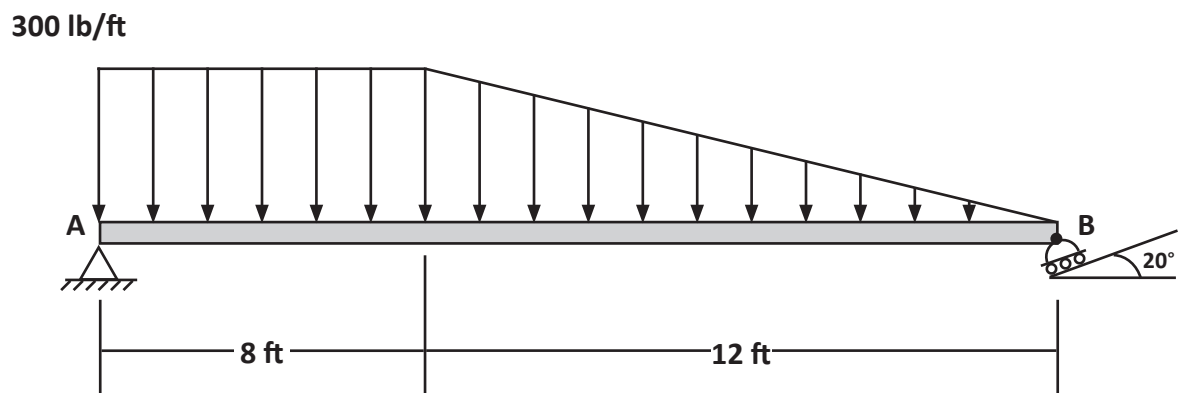

Solution.

The cantilever beam supports two loads as shown. Determine the reactions at A.

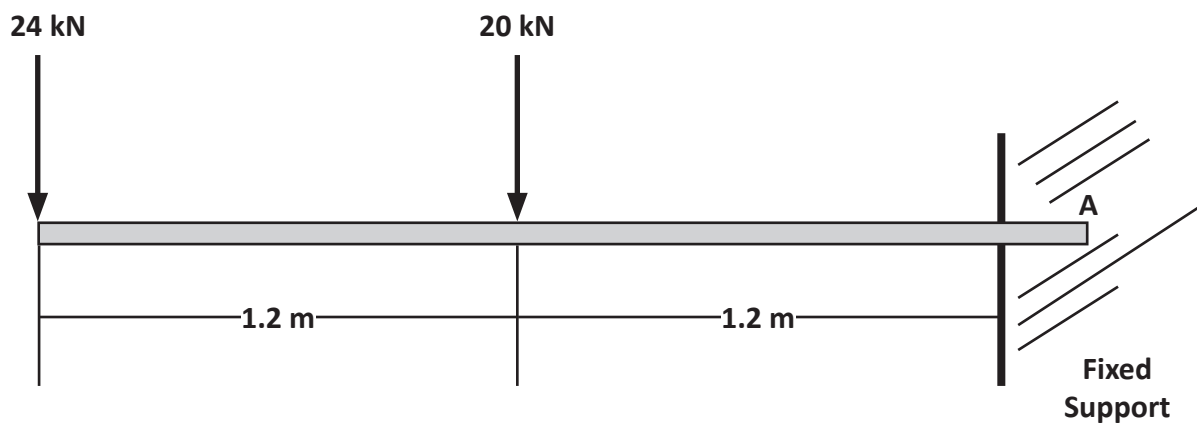

Solution.