

4-1
Introduction

Structures

A structure is a connected system of members designed to support loads safely or to transfer forces effectively. Equilibrium conditions will be applied to structures formed by pin-connected members.

Function – transmit applied loads through the structure to its external supports.

Goal of an Analysis of a Structure

Determine the force or forces that each member of the structure must resist due to application of a load system of the structure.

Two-Types of Structures Considered:

Pin-Connected Truss

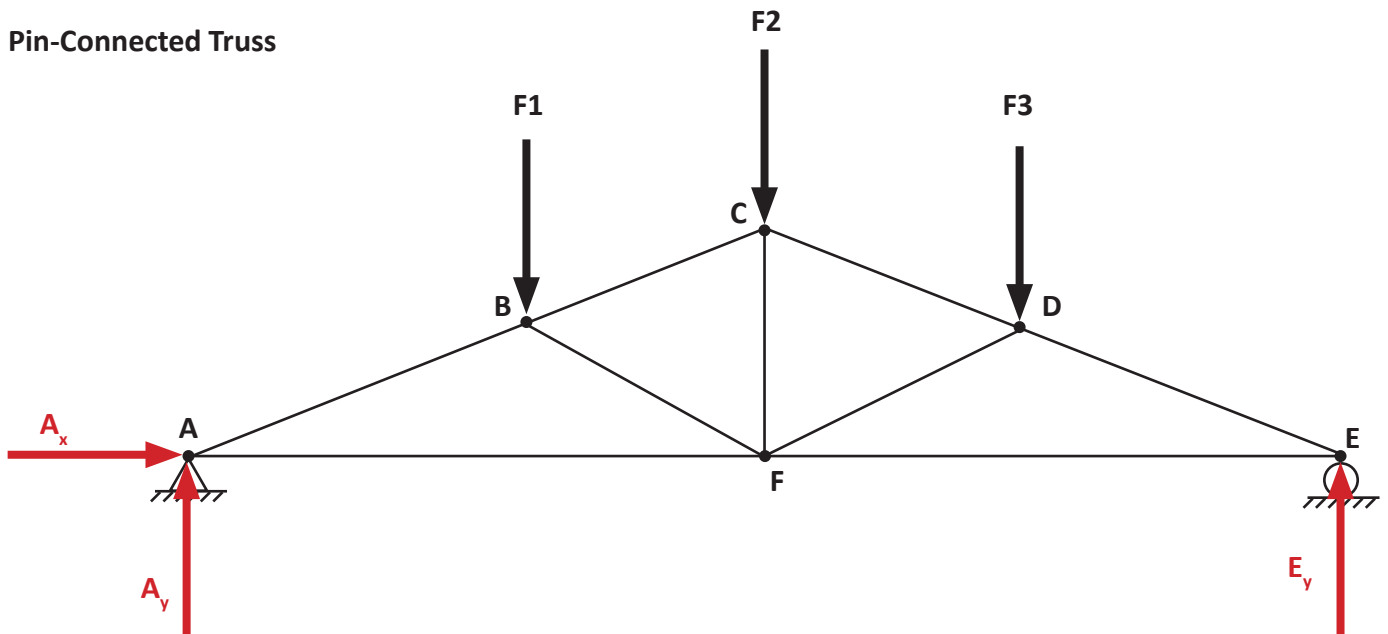

Pin-Connected Frame

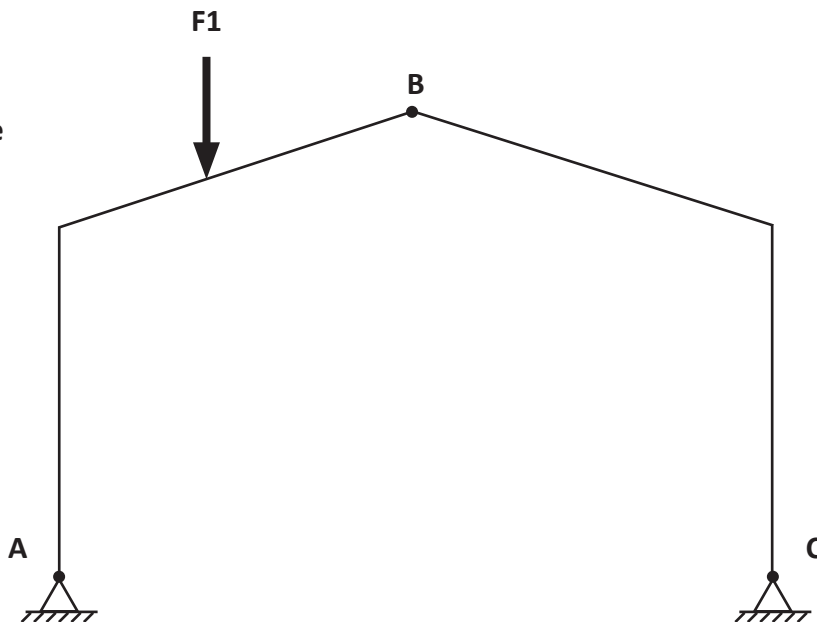

External and Internal Forces in a Structure

External Forces. The *external forces* include the weight, the externally applied forces on the structure, and the reactions from the supports. These forces are responsible for the equilibrium of the entire structure.

Internal Forces. The *internal forces* are the forces inside the structural members and are responsible for holding the structure together.

Limitation of the Principle of Transmissibility

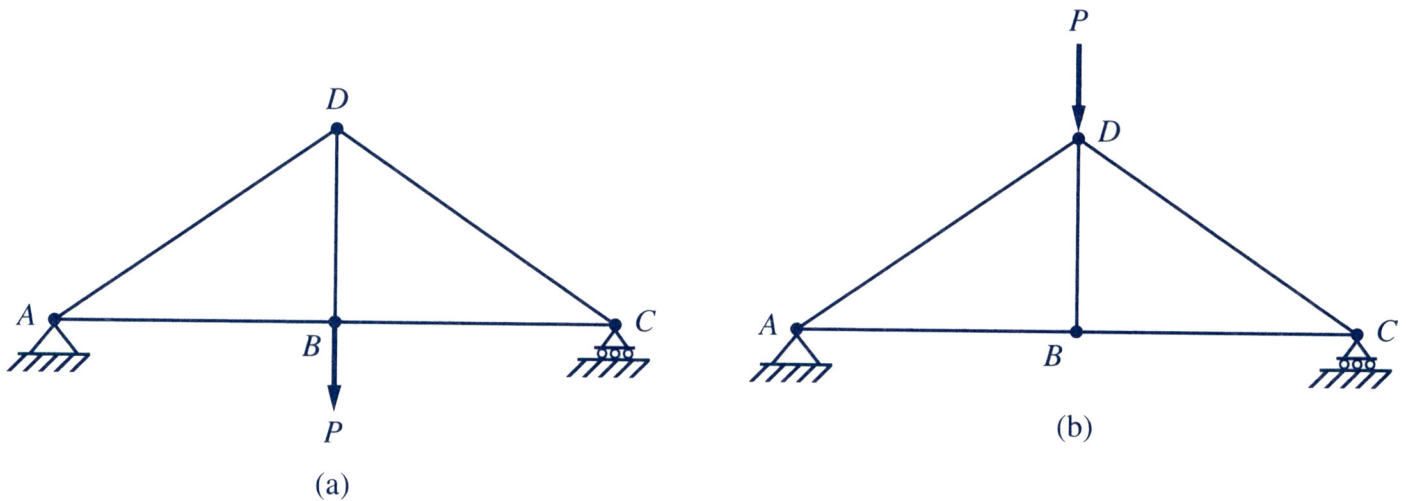

External Forces on a Structure

The external reactions at the supports A and C are not affected, whether the externally applied force P is acting at B or at D. The principle of transmissibility can be applied to the externally applied force P without altering its external effects on the rigid body.

Internal Forces in the Truss Members

The internal force in the truss member BD will be different for the two cases shown above. Therefore the principle of transmissibility is not applicable.

4-3
Trusses

A truss is a structural framework consisting of straight individual members, all lying in the same plane, connected to form a triangle or a series of triangles. The triangle is the basic stable element of the truss.

Assumptions. Two assumptions are essential for truss analysis:

1. All loadings are applied at the joints
2. The members are joined together by smooth pins.

All members are two-force members connected at their ends by frictionless pins. Truss members are subjected to axial forces only, either in Tension (T) or in Compression (C)

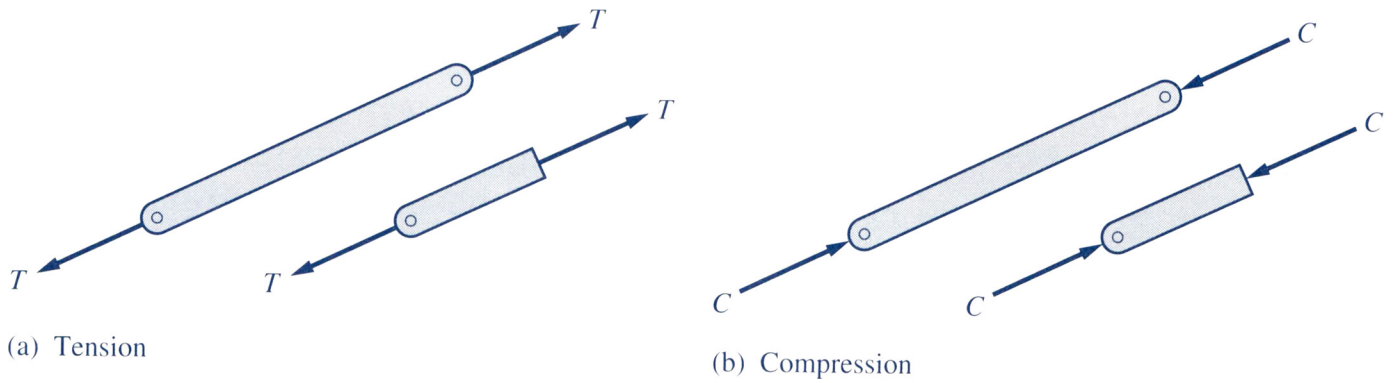

Simple Trusses

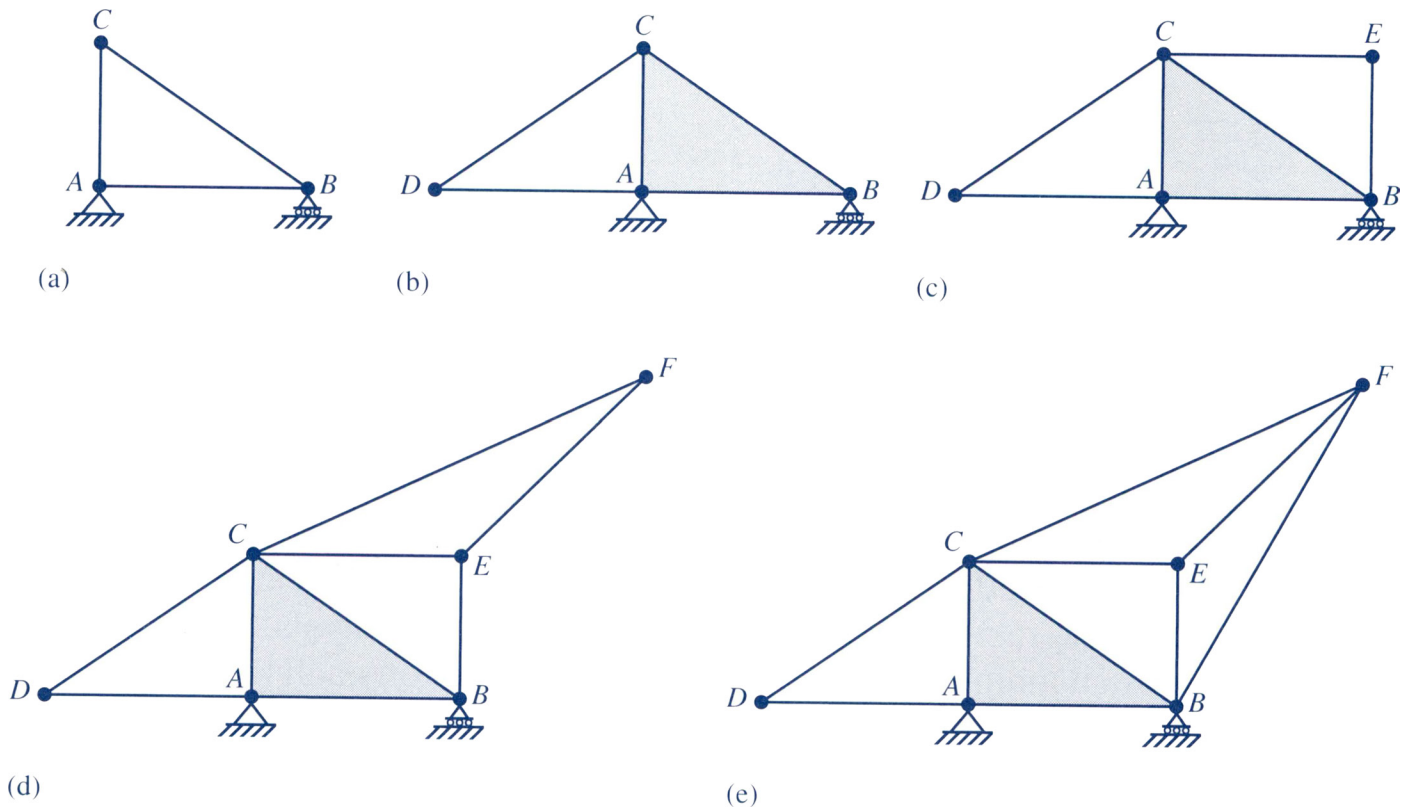

Truss Terminology

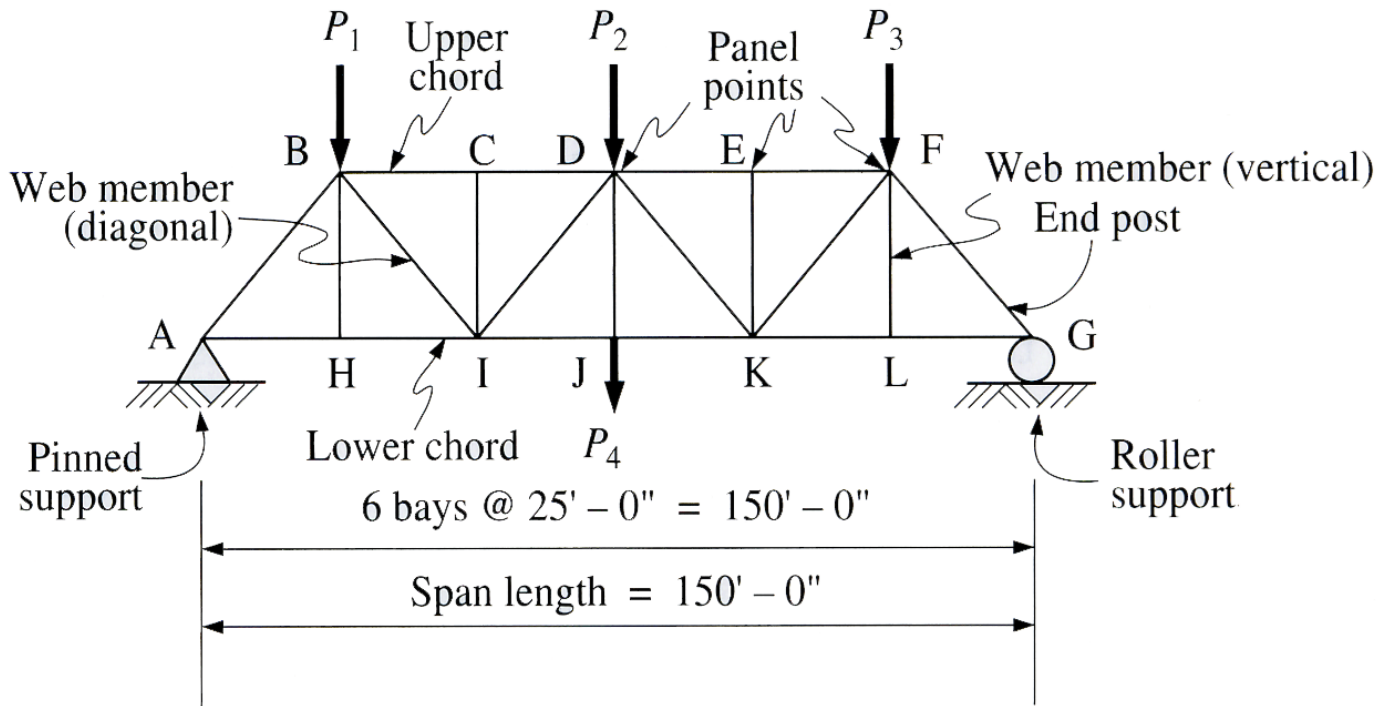

Types of Trusses

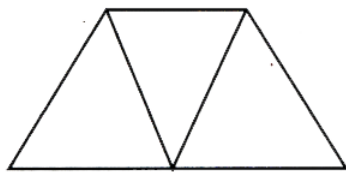

Warren truss

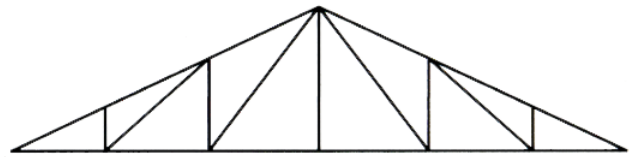

Pratt roof truss

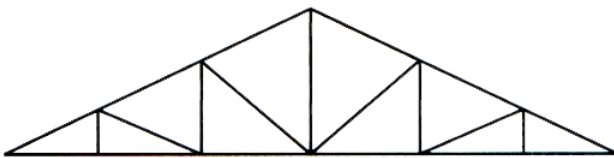

Howe roof truss

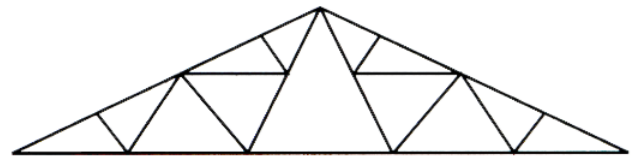

Fink roof truss

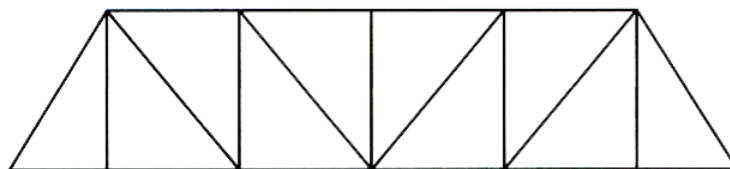

Pratt bridge truss

Forces in Members of Trusses

To simplify the analysis of a truss, the following assumptions are made:

1. All members of the truss lie in the same plane
2. Load and reactions are applied only at the panel points (joints) of the truss.
3. The truss members are connected with frictionless pins.
4. All members are straight and are two-force members; therefore, the forces at each end of the member are equal, opposite, and collinear.
5. The line of action of the internal force within each member is axial.
6. The change in length of any member due to tension or compression is not of sufficient magnitude to cause an appreciable change in the overall geometry of the truss.
7. The weight of each member is very small in comparison with the loads supported and is therefore neglected.

Based on these assumptions, and using the principles and laws of static equilibrium, the force in each member (tension or compression) may be determined by means of either of two analytical techniques:

1. Method of Joints
2. Method of Sections

Statical Determinacy – General Method for Determining

j = number of joints

m = number of members

r = number of reactions

For a statically determinate truss, the number of equations must be equal to the number of unknowns, that is, $2j = m + r$

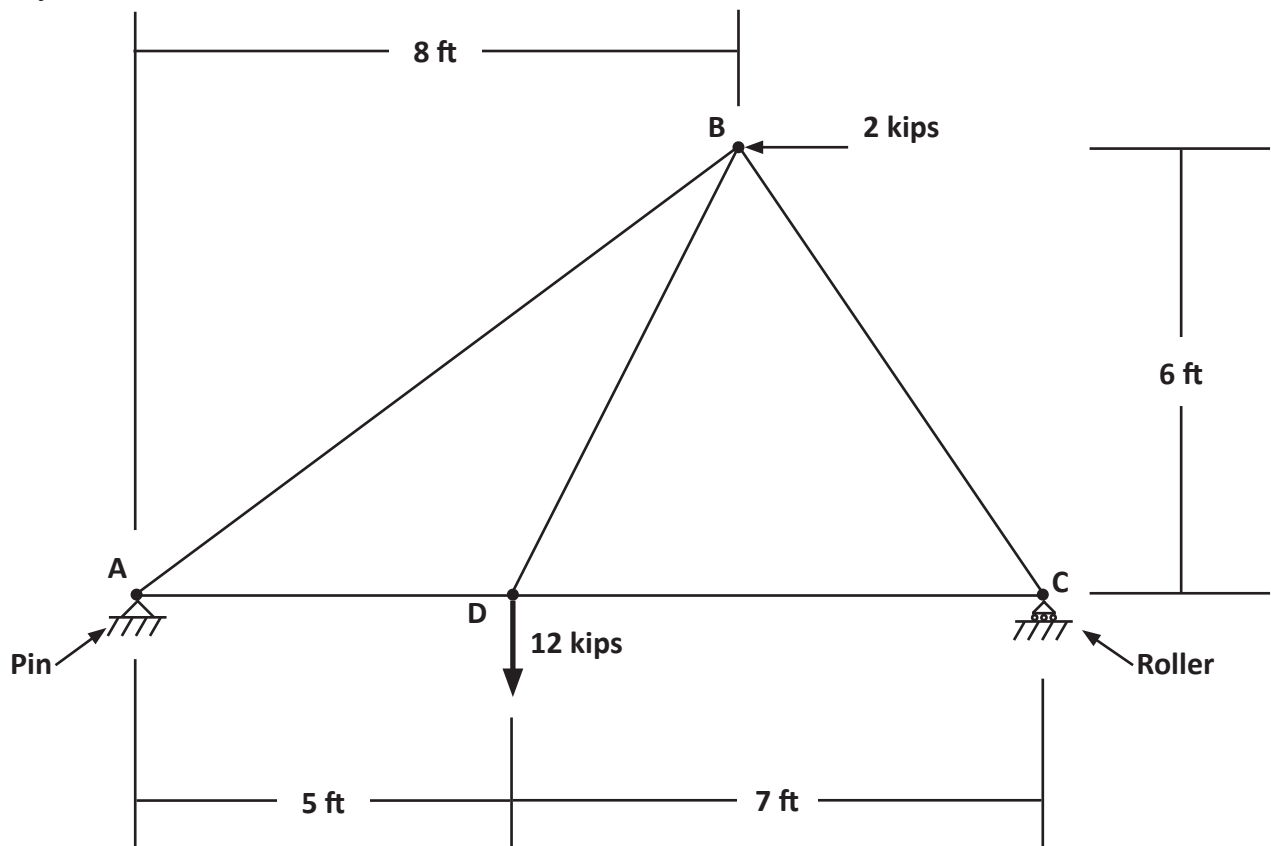

Show that the truss is statically determinate.

$j = 4$	$2j = m + r$
$m = 5$	$2 \times 4 = 5 + 3$
$r = 3$	$8 = 8 \checkmark$

The Method of Joints

- A Free Body Diagram (FBD) of a pin (joint) is used to solve for the internal forces in each member.
- The FBD is drawn by cutting through all the members framing into the joint being considered.
- Since all members of a truss are two-force members (TFM) carrying axial loads, the FBD of each joint will represent a concurrent coplanar force system.
- If the truss as a whole is in equilibrium, any isolated portion of it must likewise be in equilibrium.
- Each joint must be in equilibrium under the action of the external loads and the internal forces of the cut member that frame the joint.

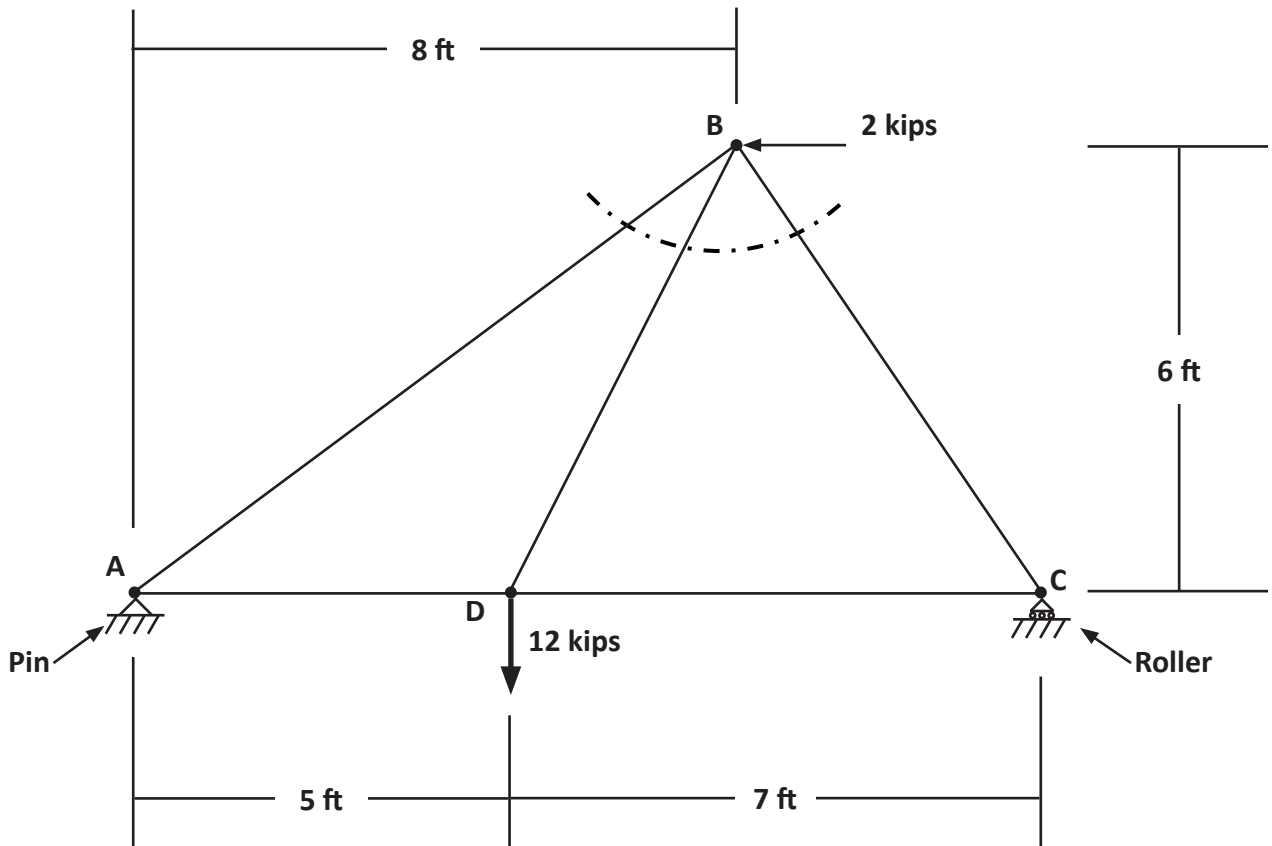

Example #1

Using the Method of Joints, find the force in each member of the truss. Using the arrow sign convention, sketch the force summary diagram.

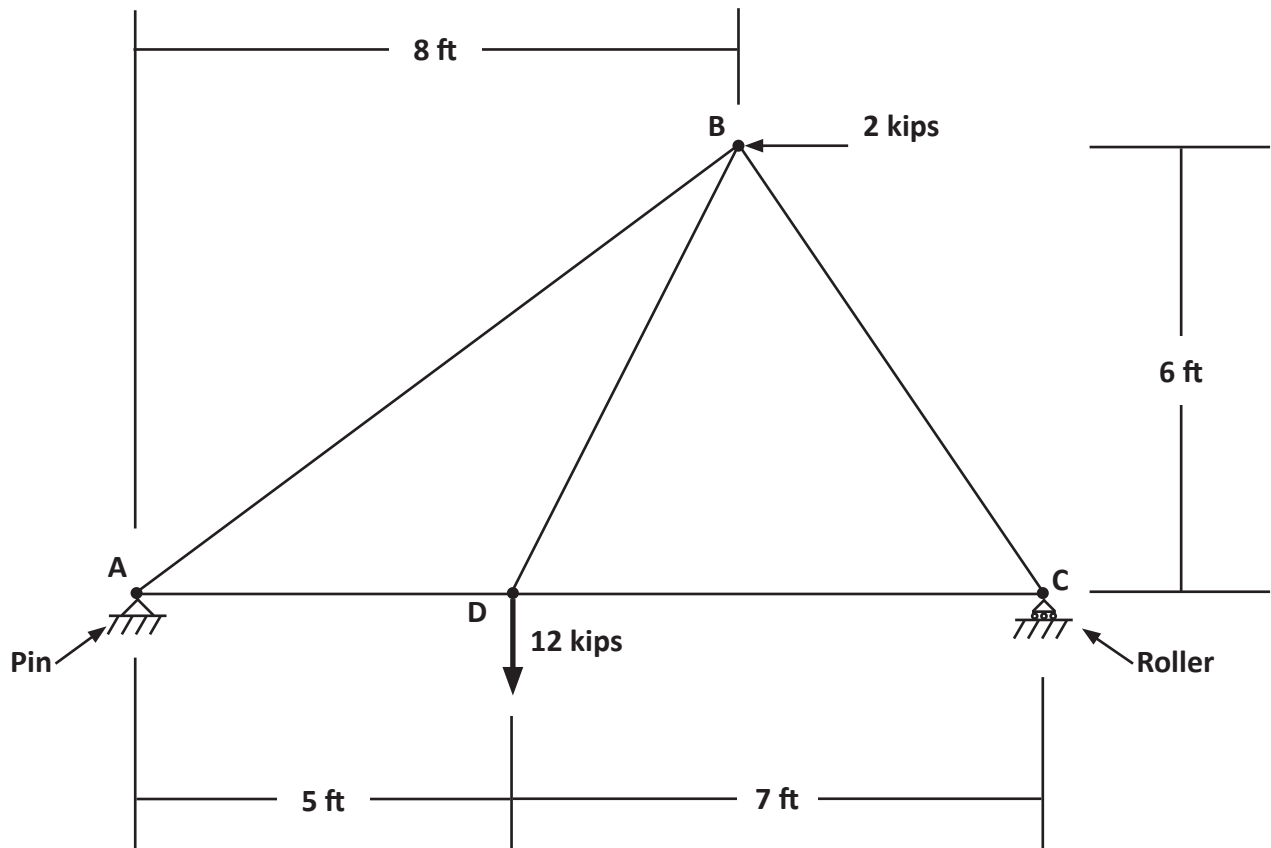

Solution.

Steps

1. Determine the unknown reactions at the supports using the FBD of the entire truss.
2. Choose a joint that has no more than two unknowns.
3. Sketch the FBD of the joint.
4. Use Equilibrium Equations to solve the unknown member forces.

$$\left. \begin{array}{l} \sum F_x = 0 \\ \sum F_y = 0 \end{array} \right\} \begin{array}{l} \text{The FBD of a truss joint is a concurrent coplanar force system.} \\ \text{Only two equilibrium equations are needed.} \end{array}$$

5. Summarize the results either on the truss diagram given or sketch a new truss diagram and indicate the member forces using the arrow sign convention.

Determine the unknown reactions at the supports A and C

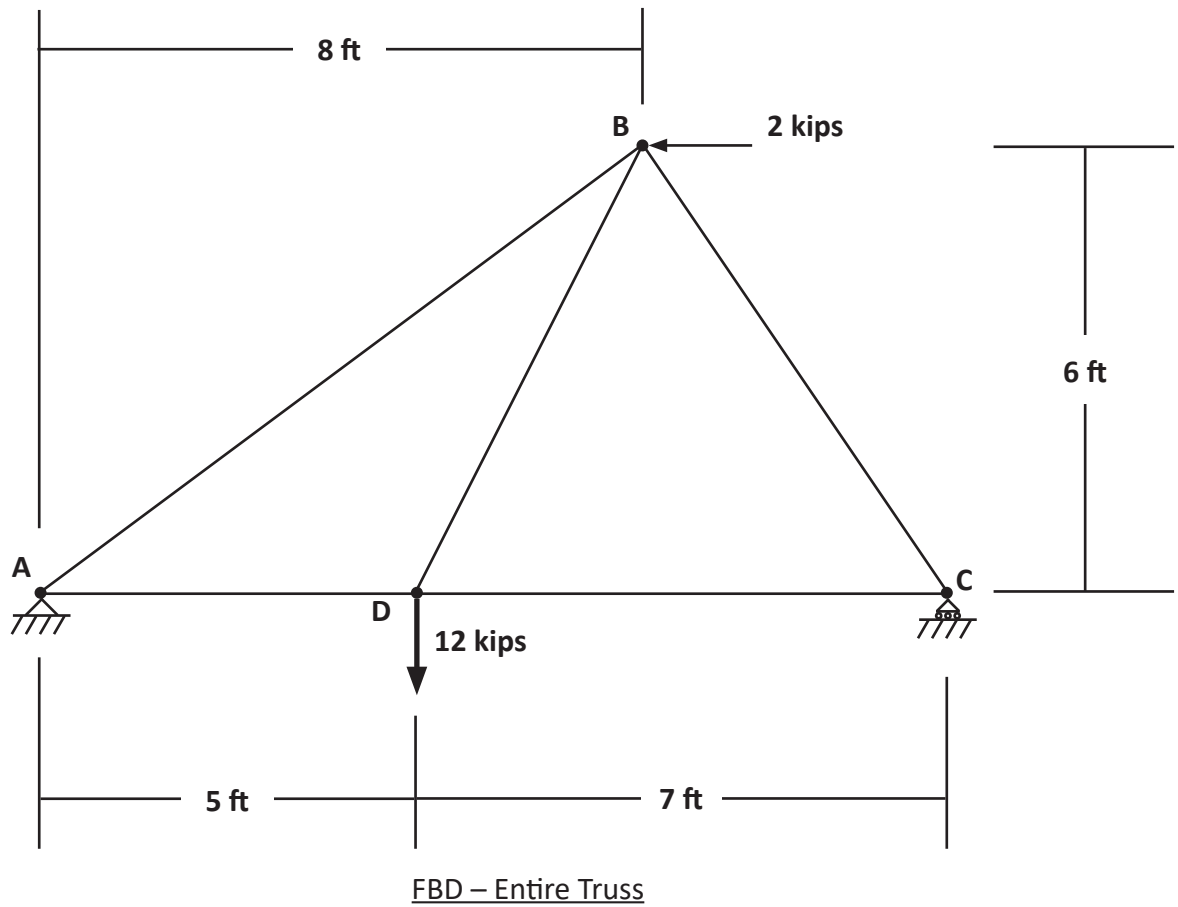

Equilibrium Equations

Joint A

Equilibrium Equations

Joint D

Equilibrium Equations

Joint C

Equilibrium Equations

Check, Extra Joint (Joint B)

Equilibrium Equations

Example #2 [Problem 4-1 textbook]

Refer to Figs. P4-1 to P4-10. Determine the forces in all members of the trusses shown using the method of joints. Indicate the results on the truss diagram using the arrow sign convention.

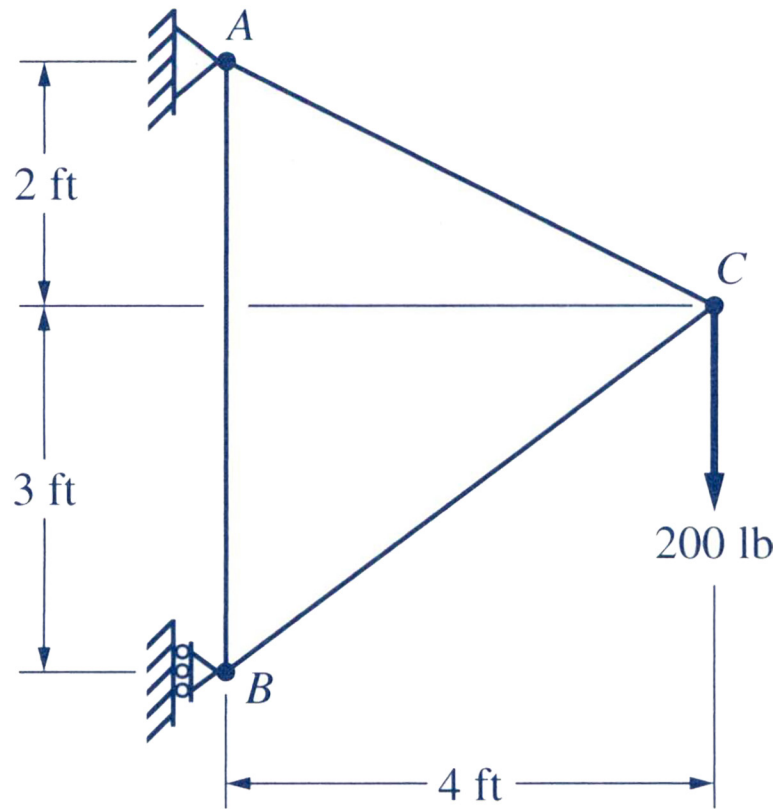

Solution.

Steps

1. Determine the unknown reactions at the supports using the FBD of the entire truss.
2. Choose a joint that has no more than 2 unknowns.
3. Sketch the FBD of the joint.
4. Use Equilibrium Equations to solve the unknown member forces.

$$\left. \begin{array}{l} \sum F_x = 0 \\ \sum F_y = 0 \end{array} \right\} \begin{array}{l} \text{The FBD of a truss joint is a } \mathbf{\text{concurrent coplanar force system}}. \\ \text{Only } \mathbf{\text{two}} \text{ equilibrium equations are needed.} \end{array}$$

5. Summarize the results either on the truss diagram given or sketch a new truss diagram and indicate the member forces using the arrow sign convention.

Determine the Reactions at supports A and B

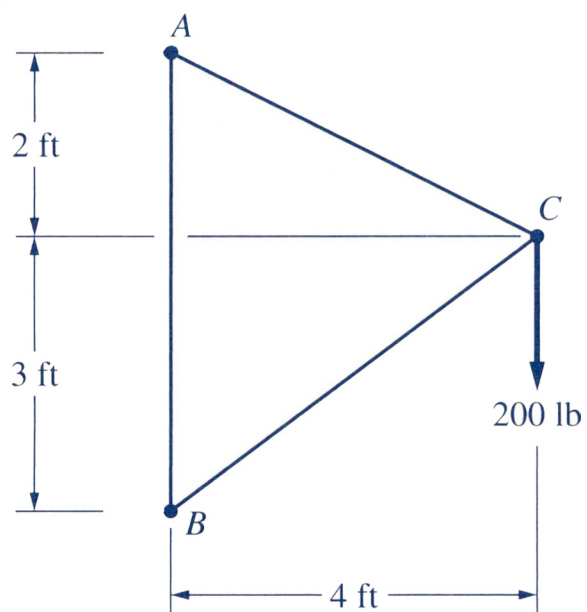

FBD - Entire Truss

Equilibrium Equations

Joint A

Equilibrium Equations

Joint B

Equilibrium Equations

Check, Joint C is a spare joint

Equilibrium Equations